

The logo for Mobile Media Inc. features a stylized, dark grey mountain range with white outlines. The word "MOBILE" is written in a large, bold, black sans-serif font above the word "MEDIA", which is also in a bold, black sans-serif font but smaller. A small "INC" is positioned to the right of "MEDIA". Below this, the words "Storage Solutions" are written in a very large, bold, black sans-serif font.

**MOBILE
MEDIA^{INC}
Storage Solutions**

**Mechanical System
Specifications
&
Detail Drawings**

1-800-784-8080

www.rolleasy.com

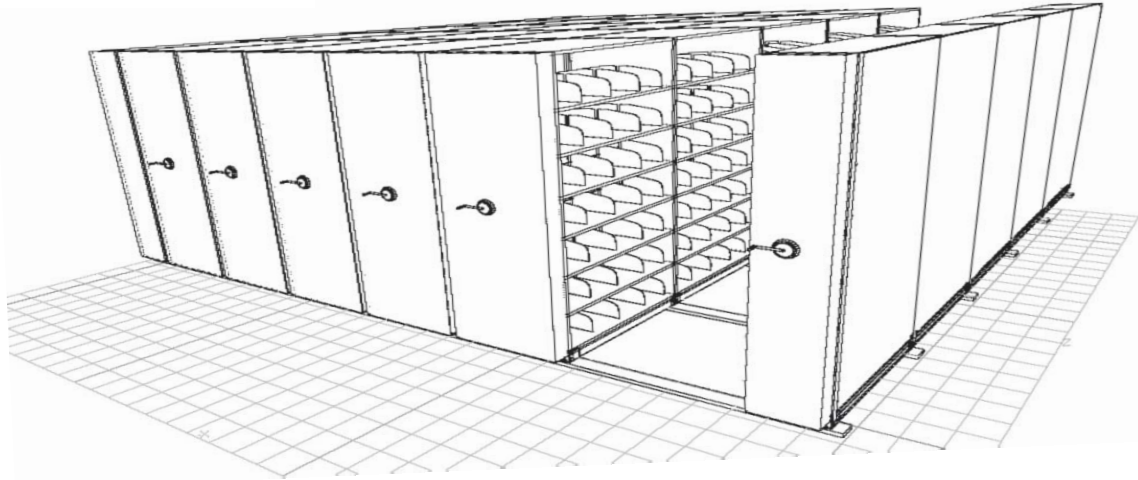

MECHANICAL SYSTEM SPECIFICATIONS

All component specifications used with a mechanical high density system are enclosed. Which components are used (floor anti-tip vs. lateral anti-tip etc.) for your specific system are dependant on the features / options you have chosen.

Please consult your drawing / project requirements to determine which components are to be used.



Carriages

Specifications

Height: 2.875 / 3.125" from finished floor

Width: To nominal shelving size

Length: To nominal shelving size

Weight Per Ft.: Approx. 1.37 lbs. per sq. ft.

Serrated: All Surfaces

The carriage frame is unit-structure aluminum designed with a load bearing channel under each shelving upright. This design is to allow for maximum distribution of the load over the floor.

The rail and channel is extruded 6063-T6 aluminum. The standard rail is 2" x .125" serrated two sides to prevent marring. The rail for the shaft driven carriage is 3 1/4" x ?. The channel is 1.875" x 1.125" with .375" solid legs for maximum load bearing without distortion.

The corners are 3" or 4" (based on carriage type) x .125" with a 1" lip above the carriage surface. The mid-plates are 3" x 3" square. Both pieces have a black enamel baked finish.

Standard maximum capacity per linear carriage foot is 858-1,144 lbs.

The carriages are not subject to distortion as there is no place where the frames are actually supporting any load bearing weight.

Carriages can be made to any size length and width to fit all shelving sizes and makes. Single unit, or back to back shelving can be used.

Having back to back shelving presents load bearing uprights in the middle of the channel. A "center" wheel is then placed in the middle of the channel to support that load.

The frame is fastened together using 1/4" and 1/2" bolts and lock nuts to ensure structural integrity and to eliminate any chance of loosening. All holes for hardware placement are machined for a .0132 tolerance to remain within commercial scale.

Carriages

Specifications

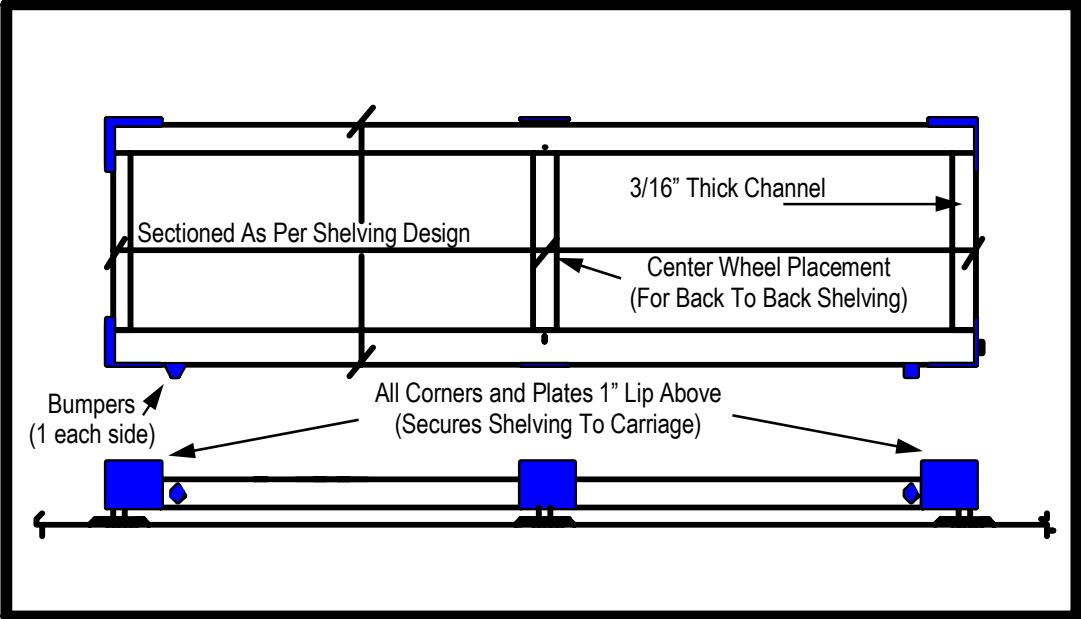
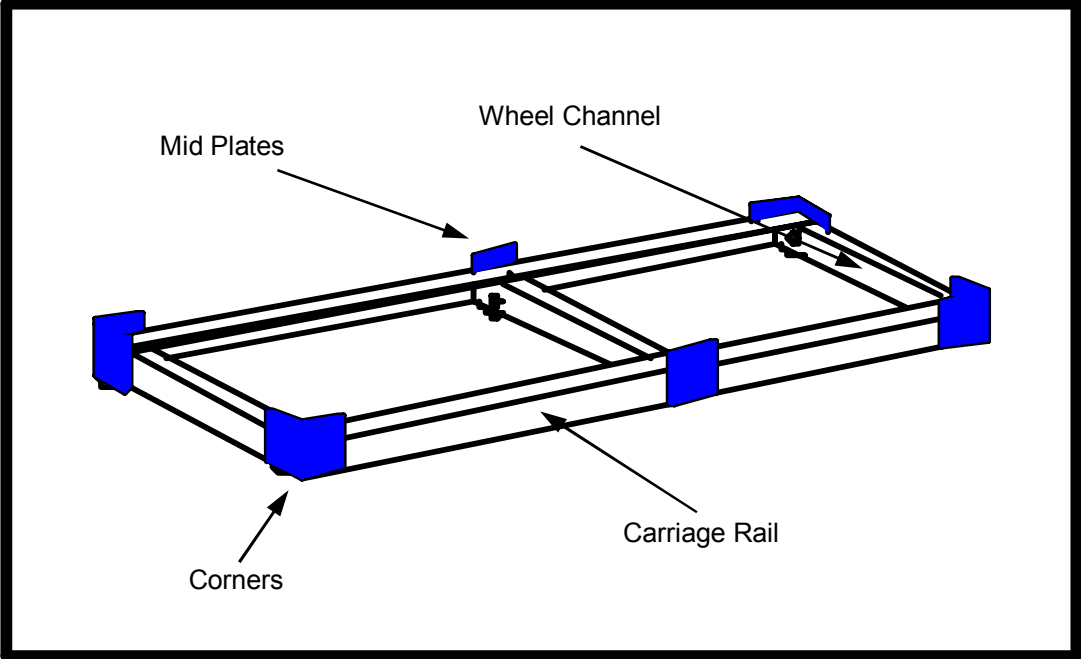

Wheel Assembly

Specifications

Height:

Width:

Length:

Weight Per Ft.: N/A

Serrated: N/A

The wheel is a 6063 permanently sealed, self-lubricating, high revolution bearing. The static load bearing capacity is 1,430 lbs. per wheel.

The guide wheels in the front channel are locked into place with oil impregnated, bronze, flange bushings.

The wheels and flange bushings are pressed into the channel and secured with a 1/2" 13 x 2" button head cap screw with a shear strength of over 20,000 lbs. The screw is then secured into position with a nylon lock nut at 110 lbs. psi.

The guide wheels allow no play in the front channel which virtually eliminates racking in the carriage.

All carriages have one set of guide wheels with the remainder of the channels housing running wheels. All running channels have the same wheel with a straight bushing to allow a tolerance of .375" in the alignment of the wheel. This allows for any inconsistencies in the floor.

The wheel rides with a running surface of less than .060" against the hardened steel insert. There is a .245" inset exposure into the track housing to prevent derailing.

There is a 45 degree bevel on the rim of the wheel for the minimum riding surface under the weight capacities required.

Wheel Assembly

Specifications

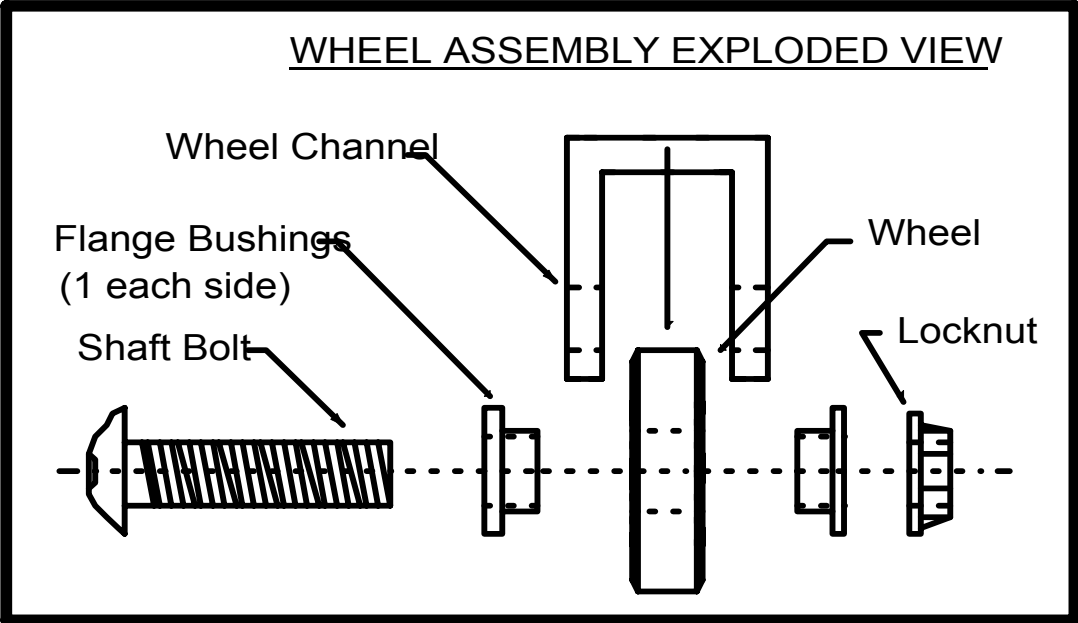
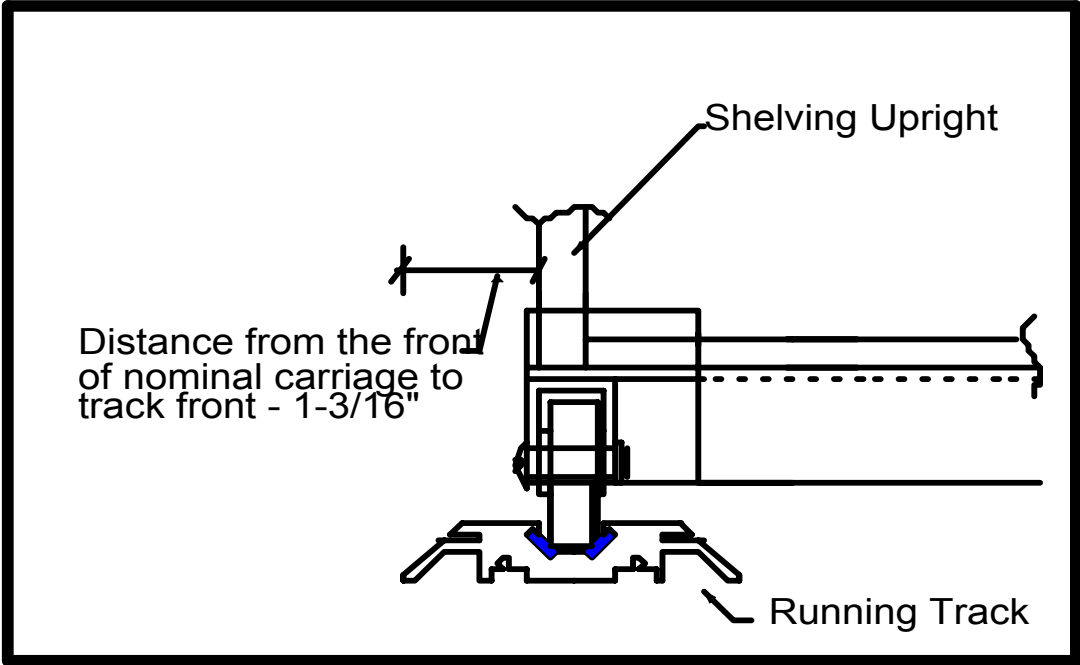



Running Track

Specifications

Height: .624”

Width: 3.50”

Length: 10’ 0” Stock

Weight Per Ft.: 1.71 lbs.

Serrated: Three sides

Accepts Ramp: Yes

The mobile running track (MT) is required under all wheel channels not requiring mechanical assist or an anti-tip system.

The track is 3.50” wide x .624” high with 45 degree bevels on both access sides to prevent tripping during use. The top three sides are serrated to prevent marring.

There is a .125” slot on both sides of the track for the insertion of a ramp when leveling the track heightens it to the point of becoming a tripping hazard.

There are two rolls of C-1095 blue tempered spring steel hardened to 56 Rockwell C scale inserted into the housing to act as a riding surface for the wheel. The inserts are held in place by .043” flanges on both sides.

There are two .187” hardened roll pins hold all splices together with a 1” inset in both sides of the splice.

Running Track

Specifications

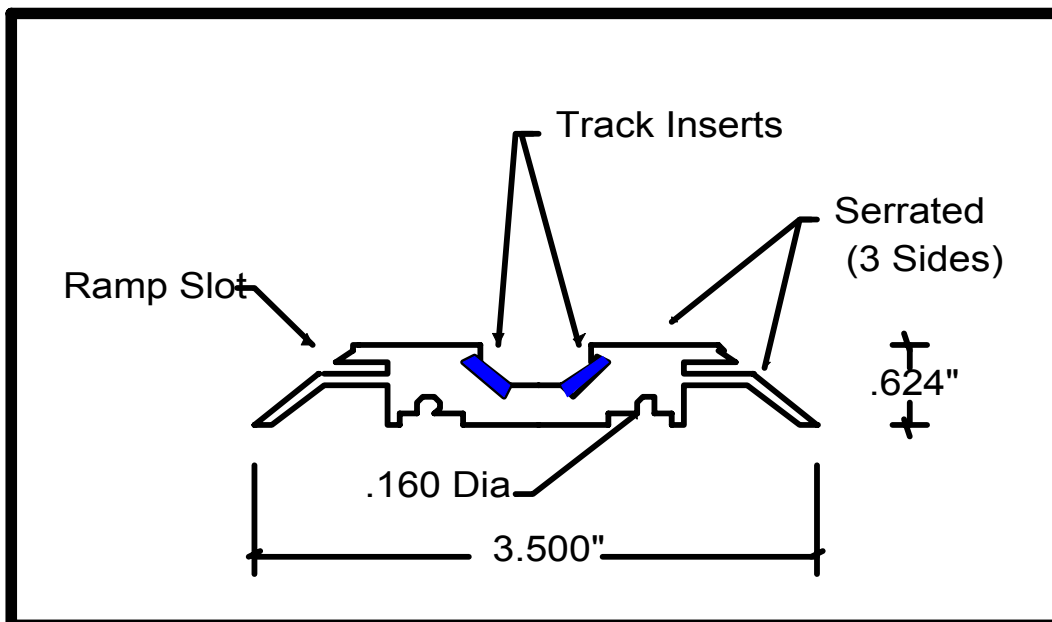
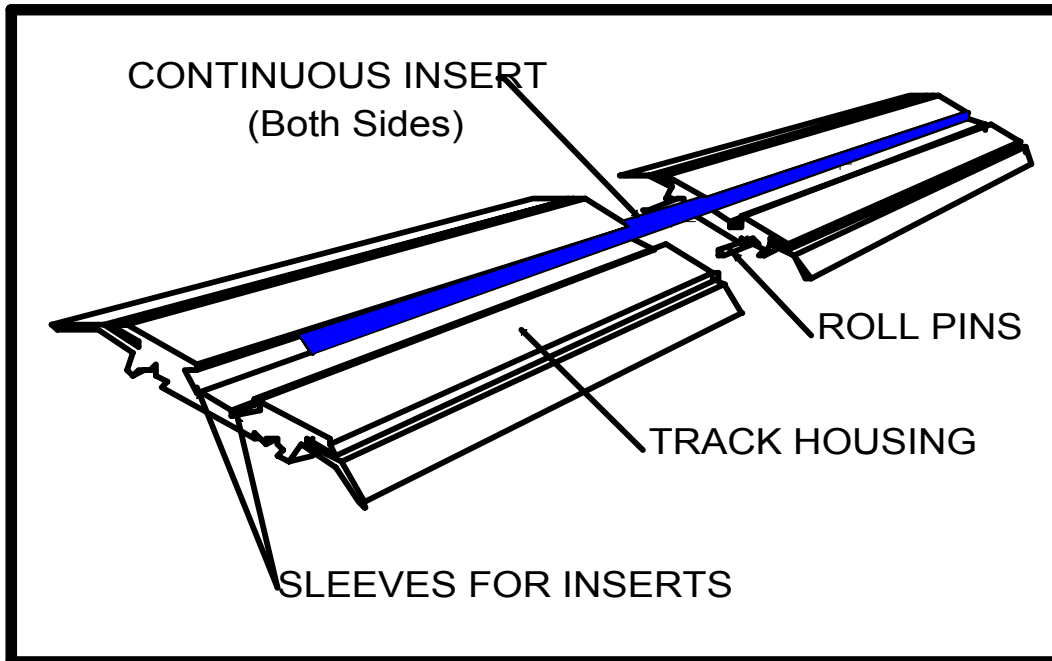



Floor Anti-Tip Track

Specifications

Height: .624”

Width: 4.871”

Length: 10’ 0” Stock

Weight Per Ft.: 1.92 lbs.

Serrated: Three sides

Accepts Ramp: Yes

When the shelving height exceeds four times the depth or when there are seismic considerations, an anti-tip (AT) system is needed.

Our floor mounted AT system utilizes two .135” angled arms attached to the corners of the carriages. The arms are perfectly aligned into an enclosed channel with a .065” return flange.

The track (TAT) offers the wheel riding surface and the channel for the anti-tip arm in uni-body form. This allows the weight of the shelving to aid in the anti-tip process as well as the procedure of installation.

The .135” AT arm has a .620” penetration into the enclosed channel.

There is an overall tolerance of .489” in the channel.

The track is 4.871” wide x .624” high with 45 degree bevels on both access sides to prevent tripping during use. The top three sides are serrated to prevent marring.

There is a .125” slot on both sides of the track for the insertion of a ramp when leveling the track heightens it to the point of becoming a tripping hazard.

There are two rolls of C-1095 blue tempered spring steel hardened to 56 Rockwell C scale inserted into the 6063-T6 housing for a riding surface for the wheel. The inserts are held in place by .043” flanges on both sides.

Floor Anti-Tip Track

Specifications

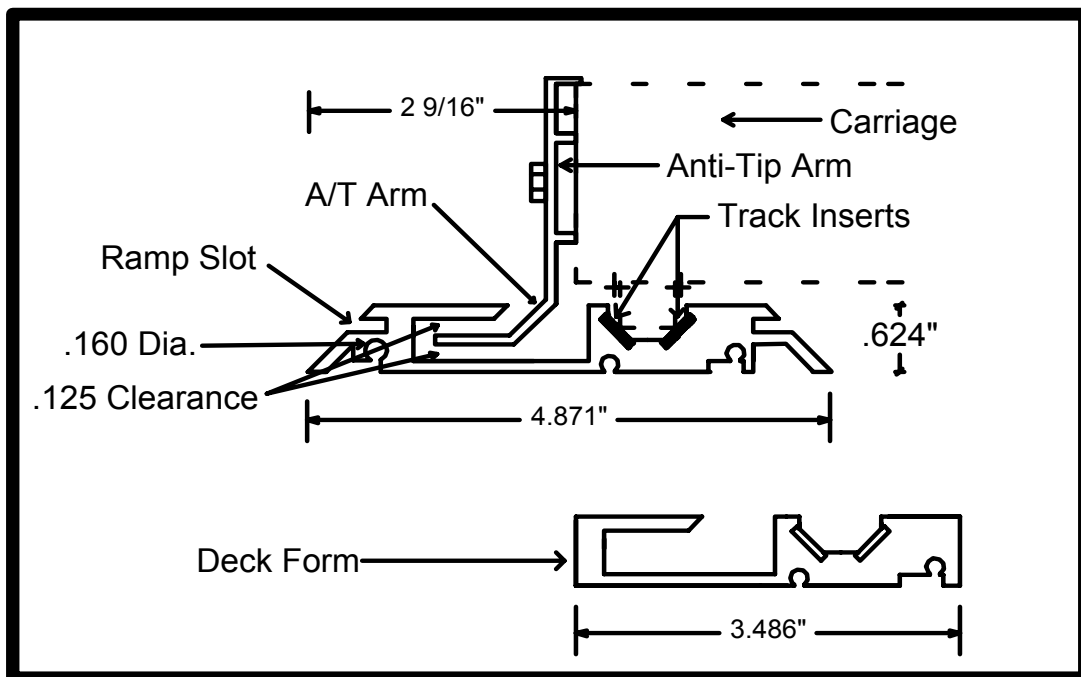
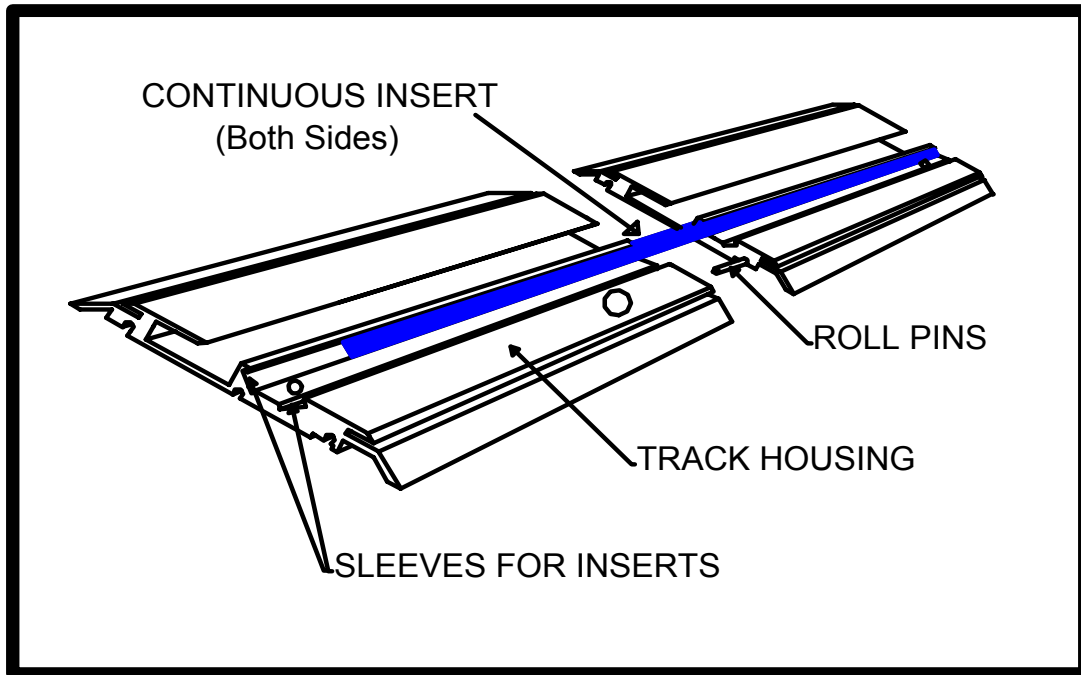



Mechanical Drive Track

Specifications

<i>Height:</i>	.624"
<i>Width:</i>	4.871"
<i>Length:</i>	10' 0" Stock
<i>Weight Per Ft.:</i>	1.92 lbs.
<i>Serrated:</i>	Three sides
<i>Accepts Ramp:</i>	Yes

When the length of carriage is too long or the overall weight in the system is too great for a manual system there is need for mechanical assist units (MD).

Our mechanical drive system utilizes a sprocket engaging a chain enclosed within a unibody track.

The track is 4.871" wide x .624" high with 45 degree bevels on both access sides to prevent tripping during use. The top three sides are serrated to prevent marring.

There is a .125" slot on both sides of the track for the insertion of a ramp when leveling the track heightens it to the point of becoming a tripping hazard.

The chain used within the track (ANSI prestretched 35) is the same as that used within our mechanical drive box.

There are two rolls of C-1095 blue tempered spring steel hardened to 56 Rockwell C scale inserted into the 6063-T6 housing for a riding surface for the wheel. The inserts are held in place by .043" flanges on both sides.

This track is used in the front of the system for carriages up to 8' long (typically) and alternates within the system for shaft drive carriages.

Mechanical Drive Track

Specifications

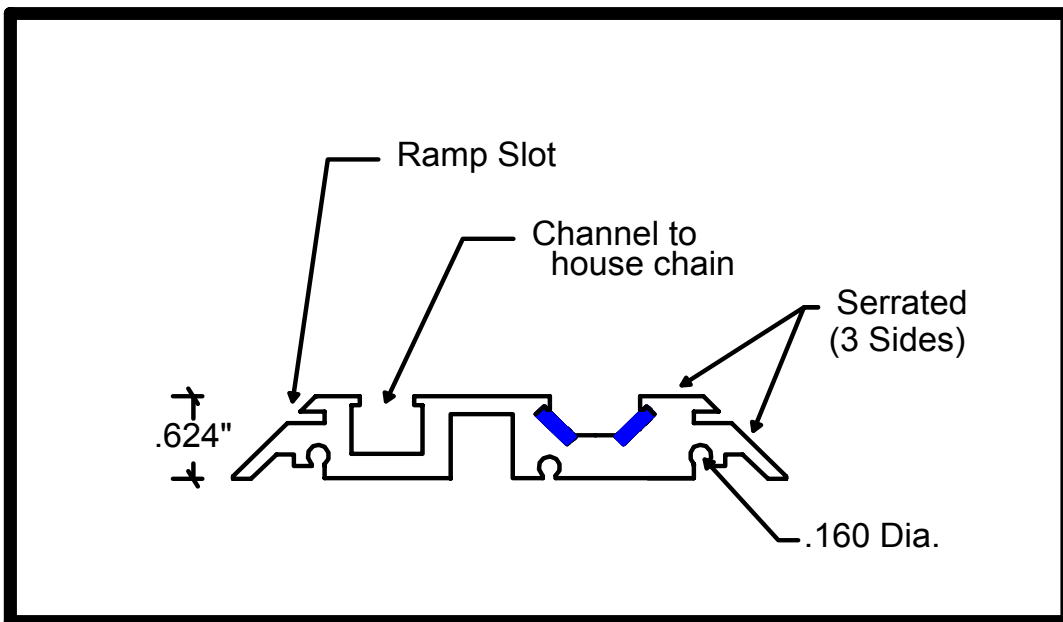
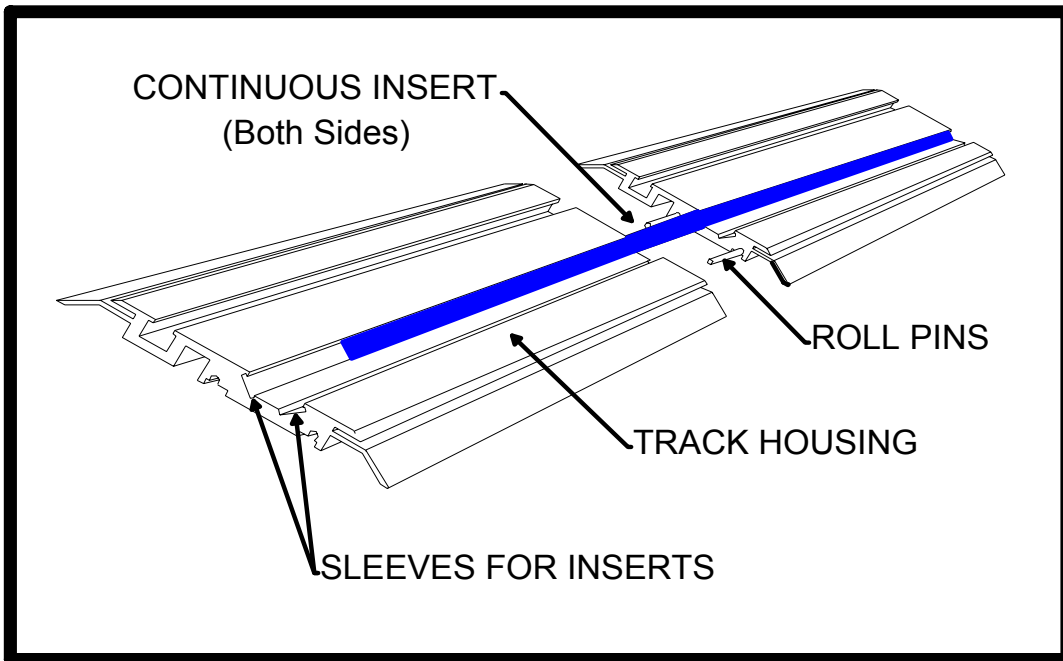



Blok Track

Specifications

<i>Height:</i>	.624"
<i>Width:</i>	1.750"
<i>Length:</i>	10' 0" Stock
<i>Weight Per Ft.:</i>	.62 lbs.
<i>Serrated:</i>	One side
<i>Accepts Ramp:</i>	No

The blok track (TBK) was designed solely for use with a deck. All other tracks have the 45 degree bevel for a smooth transition to the floor when a deck is not used.

When a flush floor is definitely going to be added the TBK has a 90 degree bevel for the easiest addition of a plywood deck.

The track is 1.750" wide x .624" high with 90 degree bevels on both access sides. The top is serrated to prevent marring.

There are two rolls of C-1095 blue tempered spring steel hardened to 56 Rockwell C scale inserted into the 6063-T6 housing for a riding surface for the wheel. The inserts are held in place by .043" flanges on both sides.

There are two .187" hardened roll pins to hold all track splices together with a 1" inset in both sides of the splice.

There is a .5" horizontal surface for the placement of anchoring hardware.

Blok Track

Specifications

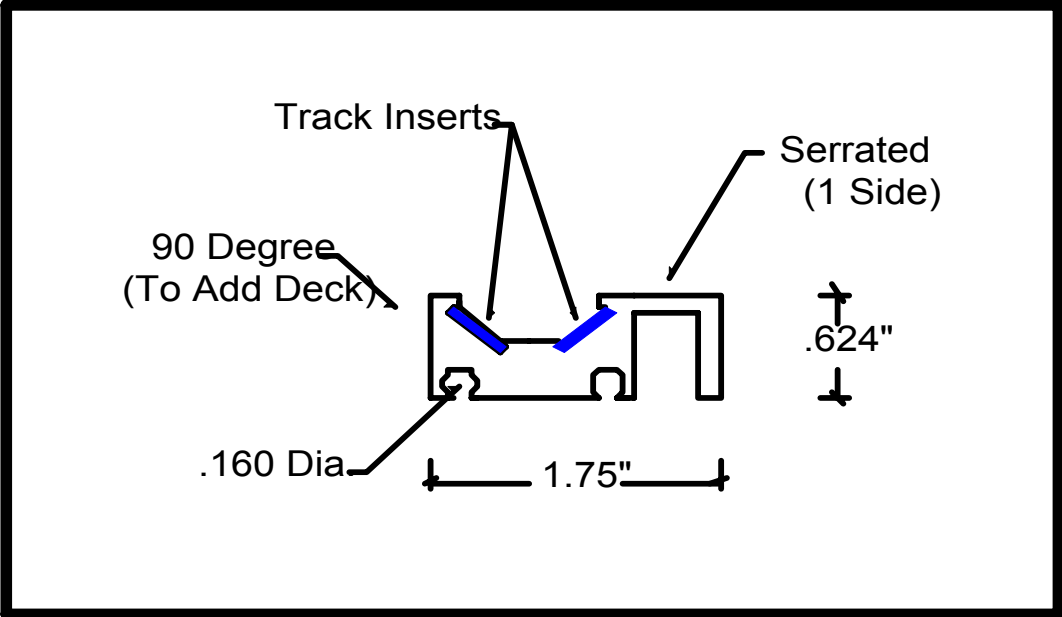
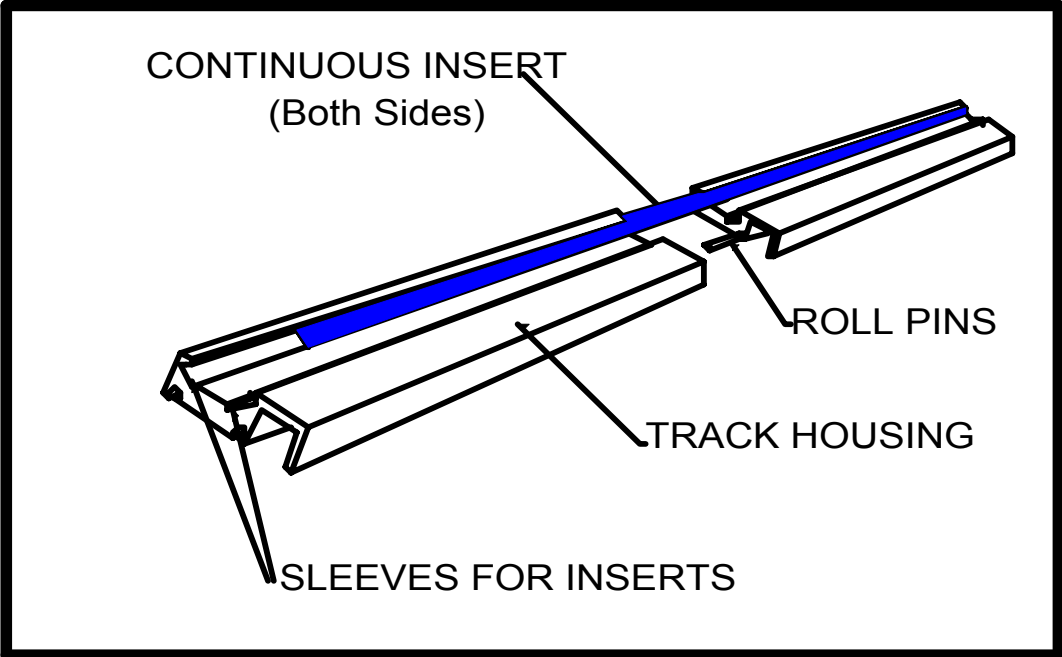



Seismic Anti-Tip Track

Specifications

<i>Height:</i>	.624"
<i>Width:</i>	4.937"
<i>Length:</i>	10' 0" Stock
<i>Weight Per Ft.:</i>	2.36 lbs.
<i>Serrated:</i>	Three sides
<i>Accepts Ramp:</i>	Yes <i>** Also available in deck form</i>

The seismic anti-tip track (TSAT) is 4.937" wide x .624" high with 45 degree bevels on both access sides to prevent tripping during use. The top three sides are serrated to prevent marring.

There is a .125" slot on both sides of the track for the insertion of a ramp when leveling the track heightens it to the point of becoming a tripping hazard.

There are two rolls of C-1095 blue tempered spring steel hardened to 56 Rockwell C scale inserted into the 6063-T6 housing for a riding surface for the wheel.

The inserts are held in place by .043" flanges on both sides.

There is a .500" x .375" opening for the insertion of an ANSI pre-stretched 35 chain for the carriage sprocket. The chain is held in place by two .094" x .062" flanges.

There are two .187" hardened roll pins to hold all track splices together with a 1" inset in both sides of the splice.

Seismic Anti-Tip Track

Specifications

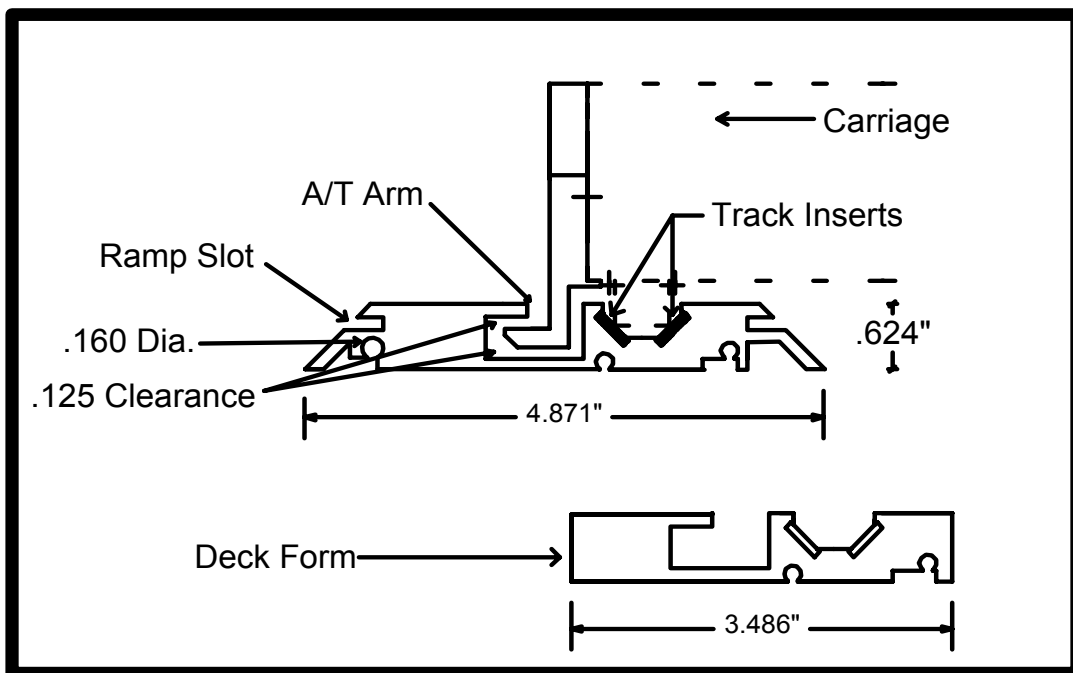
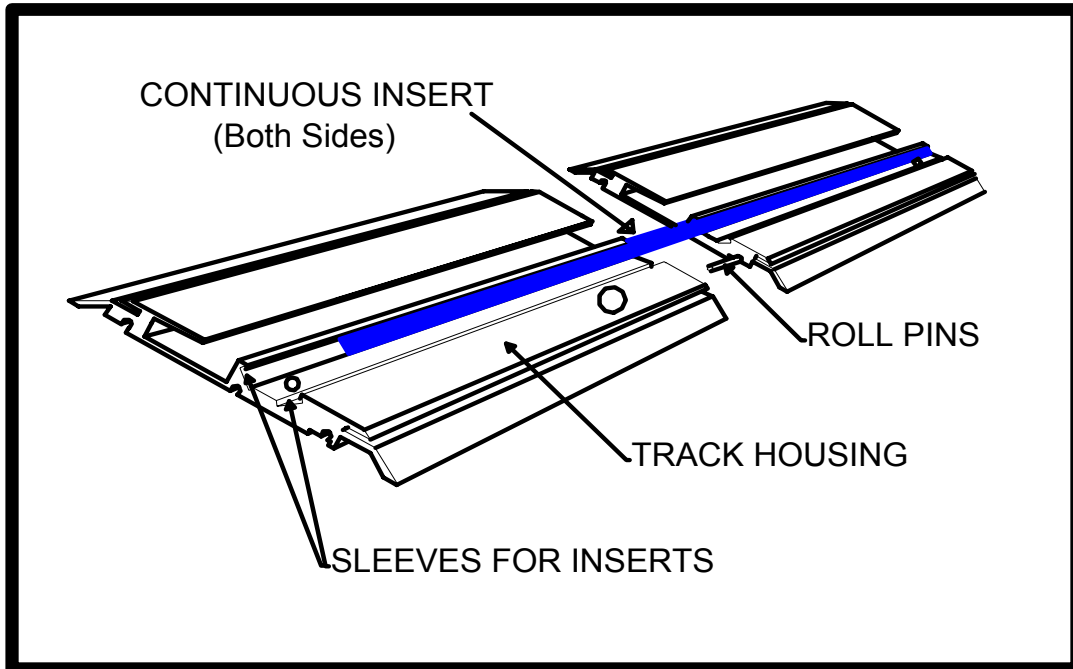



Entry Ramp

Specifications

Height: .4999”

Width: 4.929”

Length: 10’ 0”

Weight Per Ft.: .846 lbs. per sq. ft.

Serrated: One Side

When leveling the track raises it to a height where it becomes a tripping hazard an access ramp may be needed.

There is a slot in all tracks (except the Blok and ADA track) for the insertion of an access ramp.

The ramp is .156” thick 6063-T6 aluminum to prevent bowing under live load. The top surface of the ramp is serrated to prevent marring.

When inserted, the ramp extends 4.23” past the end of the track for a smooth graduation to the floor.

The ramp is held into the track slots by expandable concrete anchors secured at all ends.

Entry Ramp

Specifications

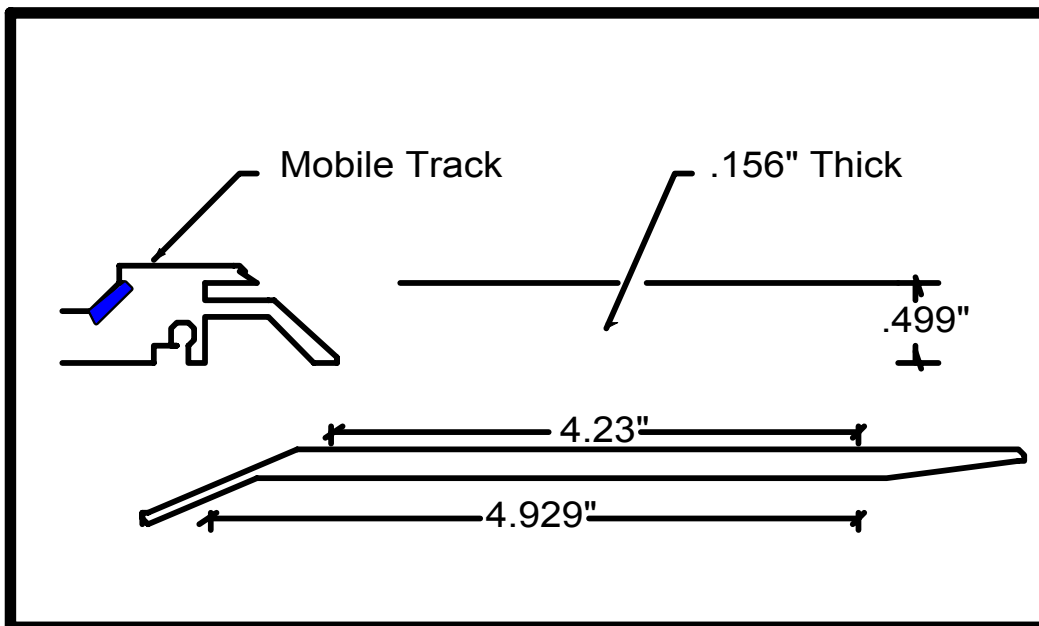
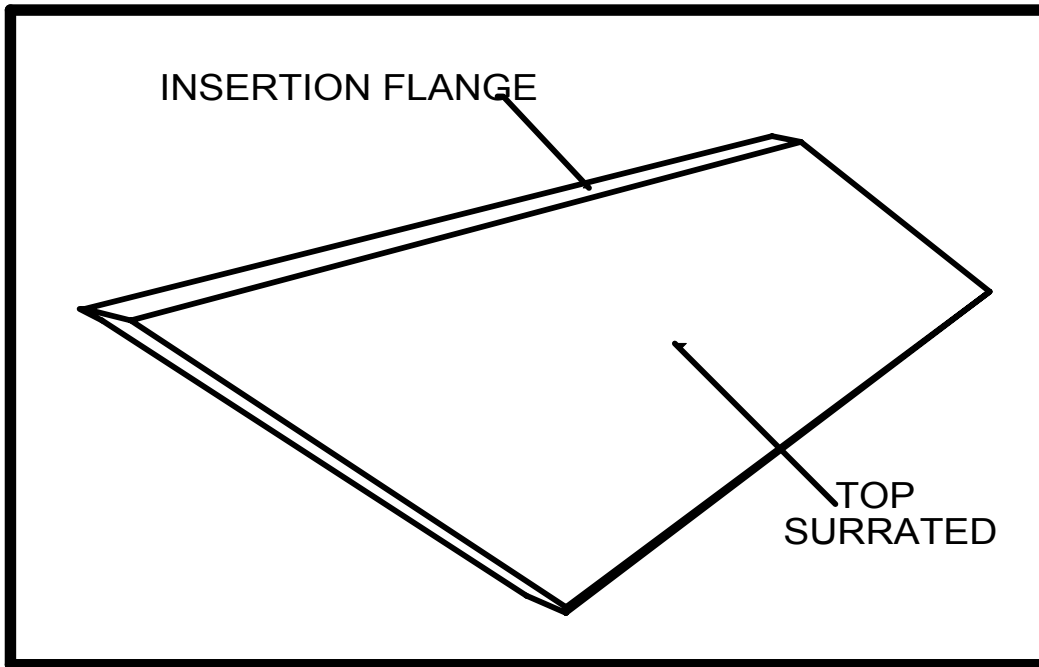



Mechanical Drive

Specifications

<i>Height:</i>	34”
<i>Width:</i>	8.75”
<i>Length:</i>	3.5”
<i>Weight:</i>	26.8 lb.
<i>Finish:</i>	Black Textured

When the length of carriage is too long or the overall weight in the system is too great for a manual system there is need for mechanical assist units (MD).

Our MD system is available in three ratios: 2000 (front and shaft driven), 4000 and 8000. The type selected depends on the system design and the overall weight of the system.

All SD (shaft driven) systems are discussed in more detail on the *Shaft Driven Specification Sheet*.

The MD housing is constructed of 11 gauge steel with a textured, powder coat, black finish. There is no visible hardware from the front, top or sides. The internal drive mechanism incorporates sprockets and chains to

transfer torque from the top handle to the drive track.

There are three (3) types of handles - standard, rotating and three spoke. All are available in two sizes to best accommodate the shelving width a 14” standard and a 9” for smaller shelving.

MFD - This system is front driven on carriages up to 16’ long (up to 8’ recommended) where the overall weight does not exceed 20 tons. There are seven (7) turns required to access a 36” aisle. This system requires lb. of pressure to move 1,000 lbs.

2000 - See shaft drive spec. sheet
4000 - See shaft drive spec. sheet
8000 - See shaft drive spec. sheet

Mechanical Drive

Specifications

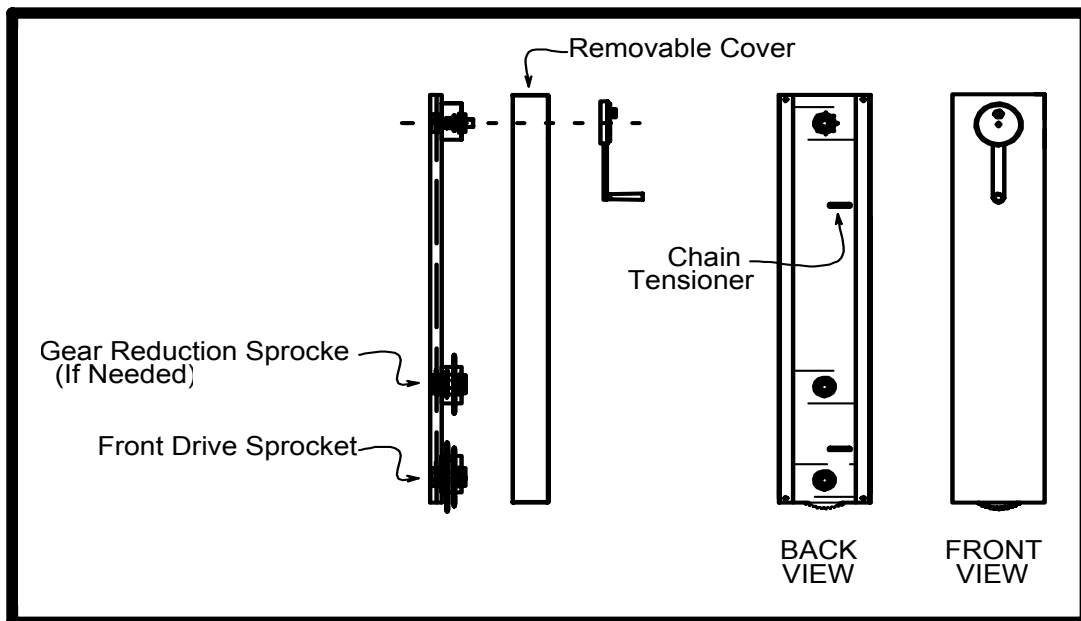
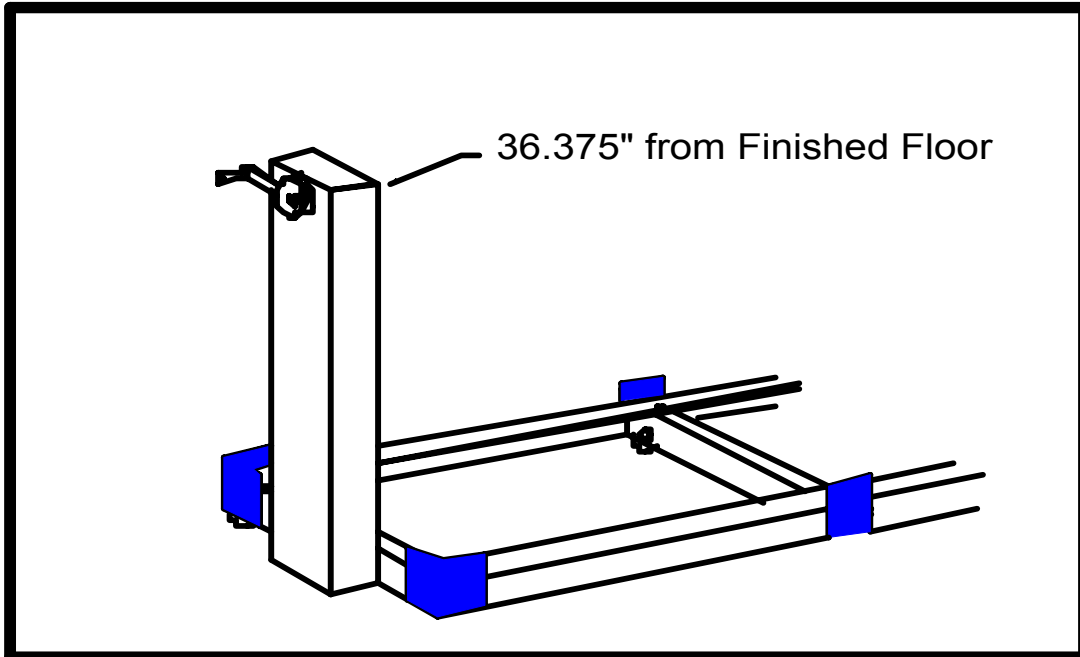

Shaft Drive

Specifications

Height: N/A

Width: N/A

Length: Nominal to shelving

Weight Per Ft.: 2.1 lbs. per linear carriage ft.

Serrated: N/A

When the length of the carriage is over 16' or the overall weight of the system is over 20 tons, there is need for shaft drive. This allows for gear reduction in the system and creates even movement throughout.

Shaft drive is available in three ratios: 2000, 4000 & 8000. The type selected depends on the system design and the overall weight of the system.

The mechanical assist housing is the same as used for front drive systems.

The internal drive mechanism incorporates two sprockets and chain assemblies for a reduction in torque.

All drives transfer the pressure to a solid 3/4" steel shaft housed in the carriage. Sprockets are then driven

throughout the carriage at each end and incrementally (depending on the carriage length).

The shaft is held in place by sealed, flange bearings and all sprockets and couplings are secured by keys and set screws.

Available S/D Ratios:

2000 - There are 5.9 turns required to access a 36" aisle allowing 1 lb. of pressure to move 2,200 lbs.

4000 - There are 13.9 turns required to access a 36" aisle allowing 1 lb. of pressure to move 4,400 lbs.

8000 - There are 26 turns required to access a 36" aisle allowing 1 lb. of pressure to move 8,800 lbs.

Shaft Drive

Specifications

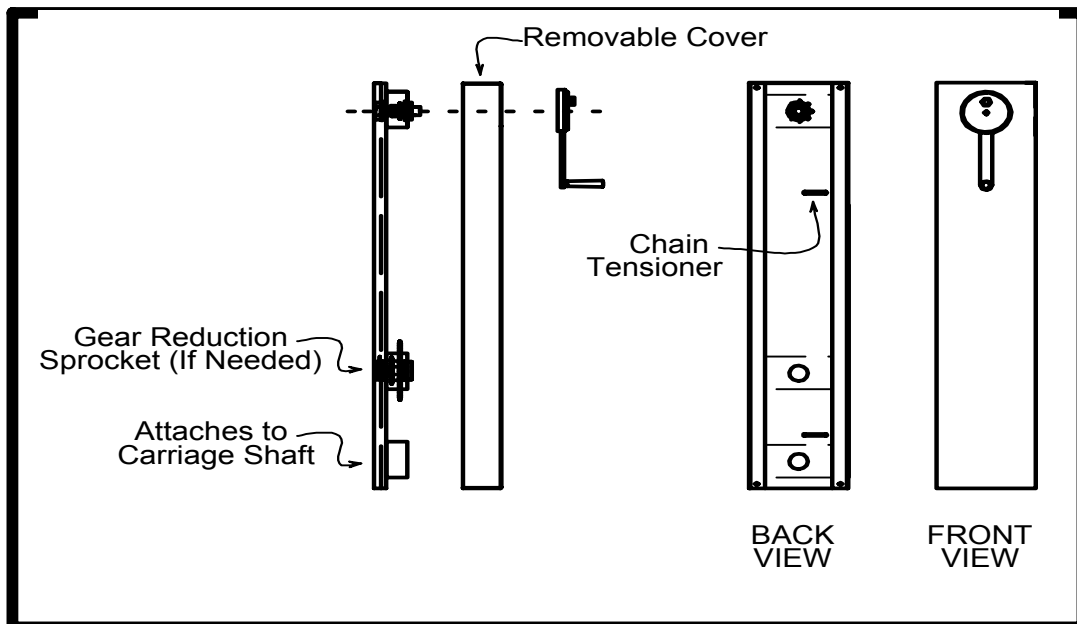
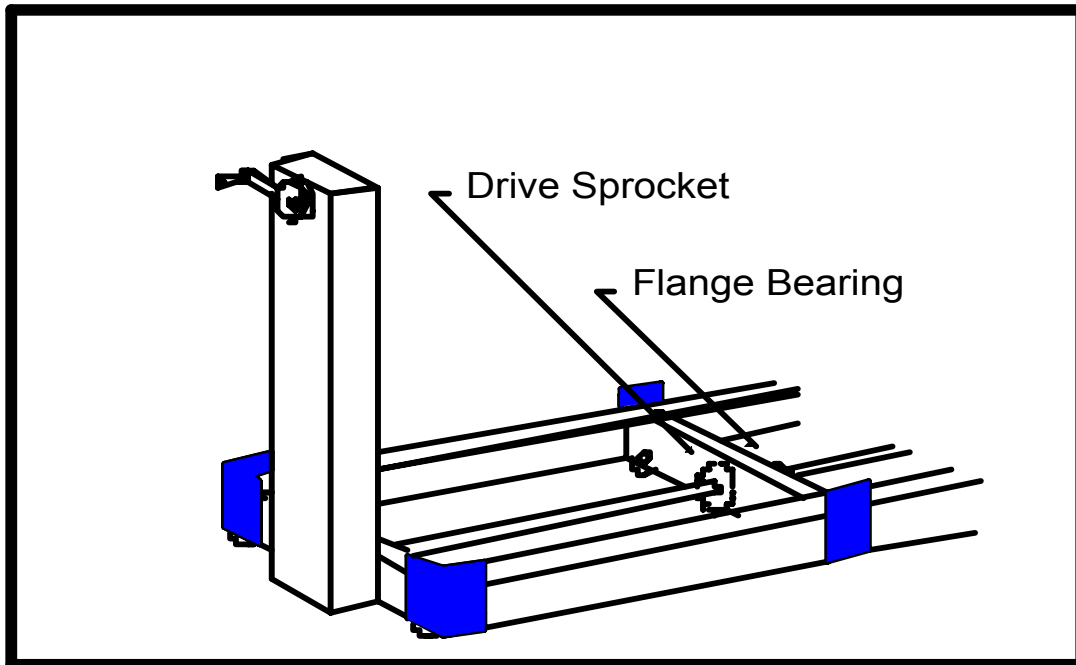



Handles & Static Bases

Specifications

Handles

Mechanical-Assist

Our stock handle is a single spoke with rotating grip handle. A three spoke handle is available upon request.

The hub is machined for a slip fit onto the shaft aligned by keyway or flat and secured by a set screw through the front of the hub.

Diameters are available in 14" and 9" to accommodate the shelving size.

Manual

Upon request manual handles can be added to any manually assisted unit. This will better establish a center of gravity for movement as well as provide a place to grab.

Our stock handles are 1/2" steel, painted black, with a powder coat finish. They are secured into place with a 10 - 24 machine screw through the corner of the upright.

The dimensions are as seen on the drawing.

Static Bases

Stationary, non-movable bases are provide upon request so there will be a uniform height throughout the system for both mobile and static shelving.

There are two heights available depending on whether or not a deck is being installed.

The static carriage is constructed out of the same materials as a regular carriage except for the wheel assembly.

Blocks of wood are painted black to match the system they are the main load bearing component. These blocks are placed and secured to the carriage channel with bolts and lock washers to prevent movement.

All shelving is mounted and secured the same way to the carriage.

Floor anti-tip is an available feature when needed for static bases also.

Handles & Static Bases

Specifications

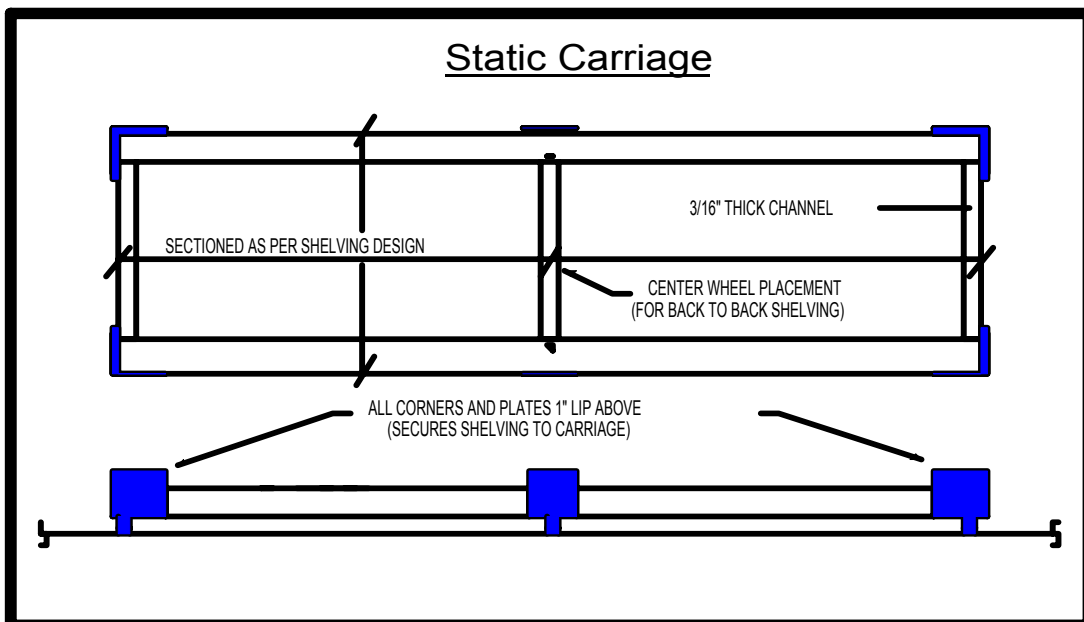
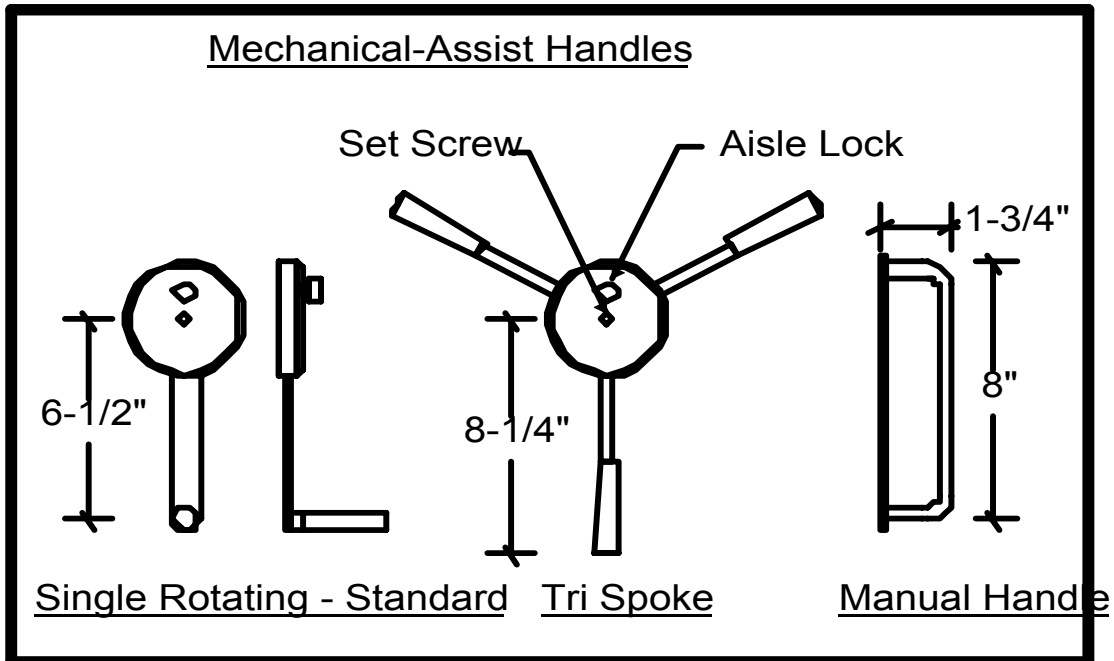



Locks & Hardware

Specifications

Locks

There are two locks available;

Aisle Lock - To prevent access while system is being used.

System Lock - To prevent access by unauthorized personnel.

Aisle Lock

Available with mechanically assisted systems only. This is an indexing plunger with a .28" insertion into the mechanical housing. The locking mechanism is activated by pushing the plunger directly into the housing. This plunges a steel rod through machined holes in the mechanical housing.

System Locks

Available for both manual & mechanical systems. This is a keyed plunge lock installed on the carriage. When pushed a steel rod is inserted into an aligned hole in the track.

After the system is installed all the carriages are placed to one side. This shows the position for the hole to align to the lock.

Also available for mechanically assisted systems is a keyed lock placed directly in the handle hub.

Hardware

The track is normally installed (unless a special request has been made) with a 2" expandable concrete anchor at each end and a 1-1/2" anchor at all splices.

After aligning and drilling the hole into the floor the anchor is inserted through the end stop, end cap and track into the floor. Hammering the anchor down (normally after leveling the tracks) then secures all parts into place.

The end stop has a permanently installed washer to prevent movement or tearing from pressure.

The end cap keeps the inserts from sliding out of position.

Upon request or in seismic areas a 3.25" wedge anchor is used for further penetration into the ground.

High pressure, tempered roll pins hold all splices together with a 1" penetration on both sides.

Locks & Hardware

Specifications

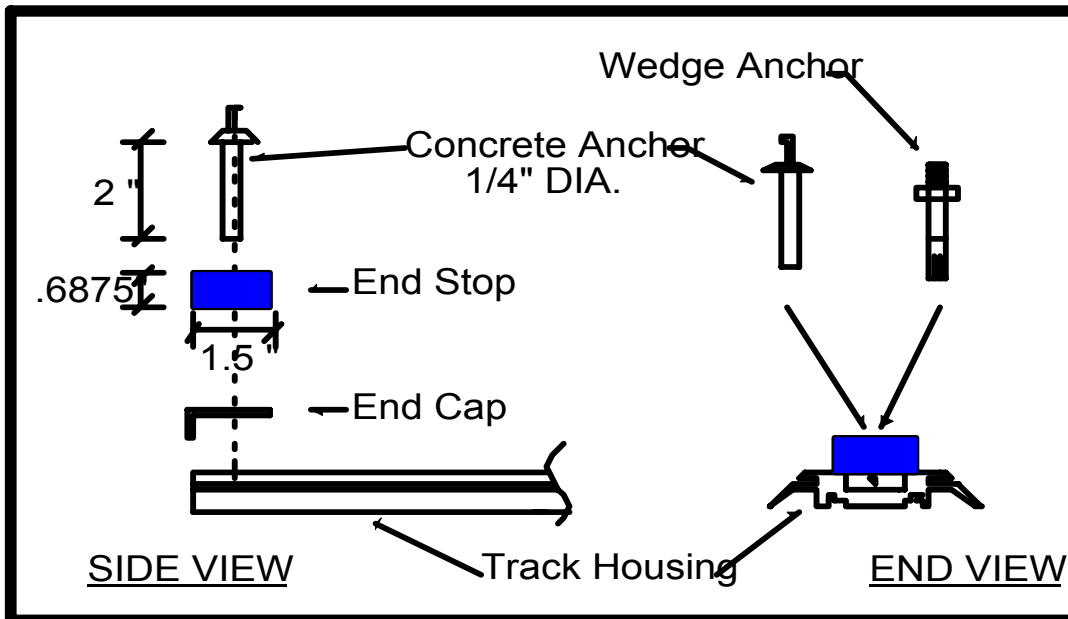
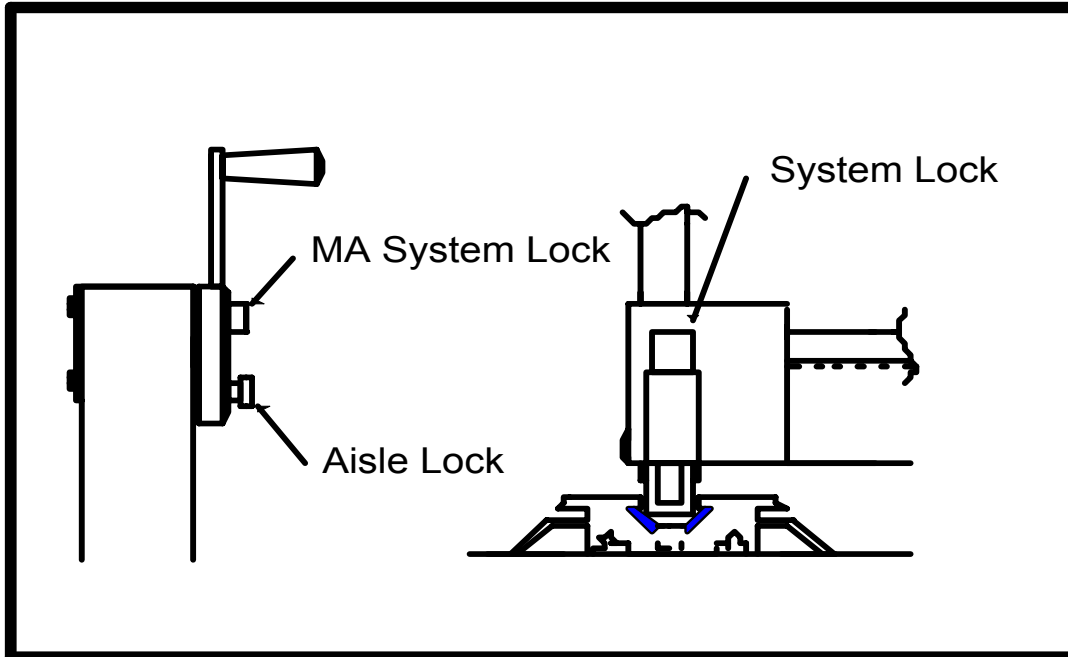

Wrap End Panel

Specifications

End Panel

The wrap end panel is used solely for enclosing the mechanical assist housing.

All sides and the front are 3/4" thick particle board. The front and sides can be laminated with most horizontal grade laminates available.

There is a locking plate available to use with the aisle lock mechanism on the mechanical assist.

The wrap panel can be secured to the shelving and carriage by screws going through the shelving unit itself or angles attached outside the shelving or filing unit.

The carriage is made standard length with the front set of corners notched to allow the shelving to meet the panel the entire height of the unit.

Face Panel

The face panel is for a decorative finish on the end of the shelving run.

This is a 3/4" thick panel finished in most standard laminates with matching heat tape or plastic corners.

This is secured to the end of the shelving run for both manual and mechanical systems.

When used with mechanical systems the mechanical assist housing is attached to the face panel as opposed to the shelving itself.

There is a locking plate available to use with the aisle lock mechanism on the mechanical assist.

The carriage is made standard length plus 3/4" to accept the face.

Wrap End Panel

Specifications

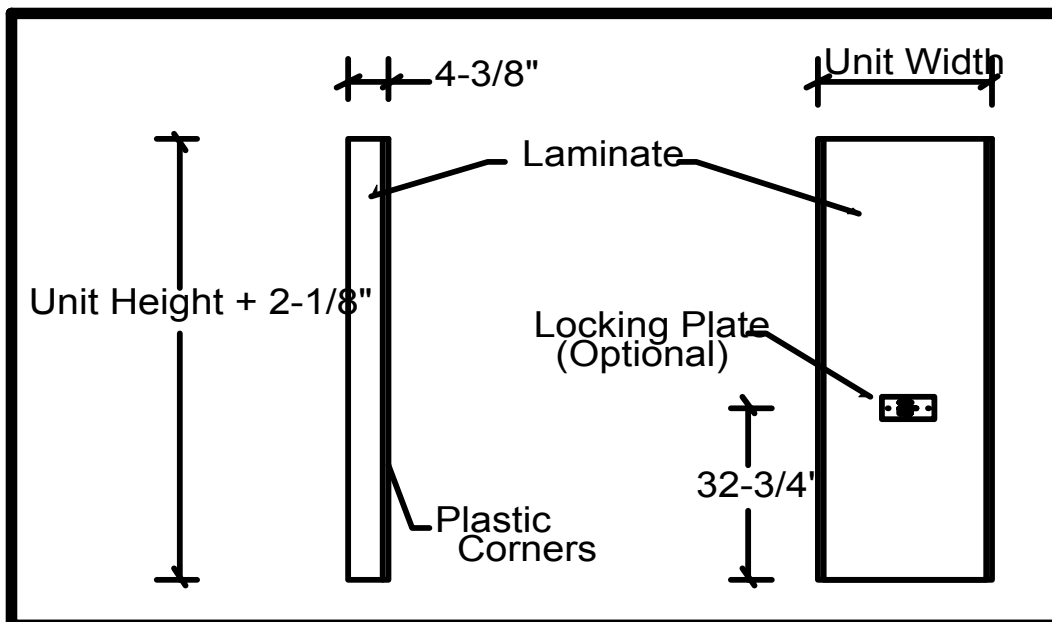
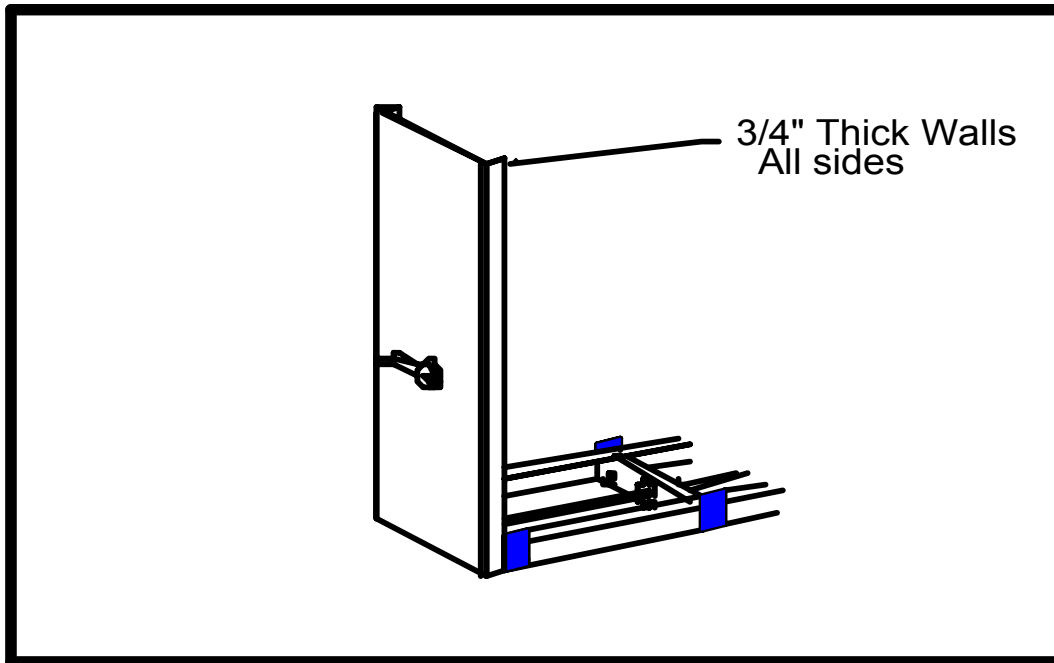



Carriage & Track Growth

Specifications

Carriage Growth Dimensions

After the shelving size is determined the standard growth in both directions is 1/4" to allow for any inconsistencies in the shelving.

The carriages are manufactured to within 1/32" tolerance to any size determined for an open or tight fit. The comfort level of deciding this is dependent on the exactness in the shelving manufacturing method.

Carriages can be made oversized up to 3/4" to allow for this, the corners and center plates are still more than able to keep the shelving in place.

The shelving sections being used to make a run (a 12' long carriage for example) need to be stated so mid channels can be placed accordingly.

The standard carriage height is 2-7/8" off the finished floor (shaft carriages are 4-1/8").

*This is based on a level floor. Any raising of the track for leveling will change this measurement.

Track Growth Dimensions

Track lengths can also be made to any length to allow for any size aisle requested.

To determine the exact aisle in a specific space:

1. Add 3" for both end stops at each end of the track.
2. Add the width of the carriage plus 9/16" times the number of the carriages in a run.**
3. Subtract this number from the length of the track and this is the aisle space.

*Or to get a specific aisle space make the additions necessary and add the aisle space required. This will total the needed track length.

** For carriage size see opposite section.

Carriage & Track Growth

Specifications

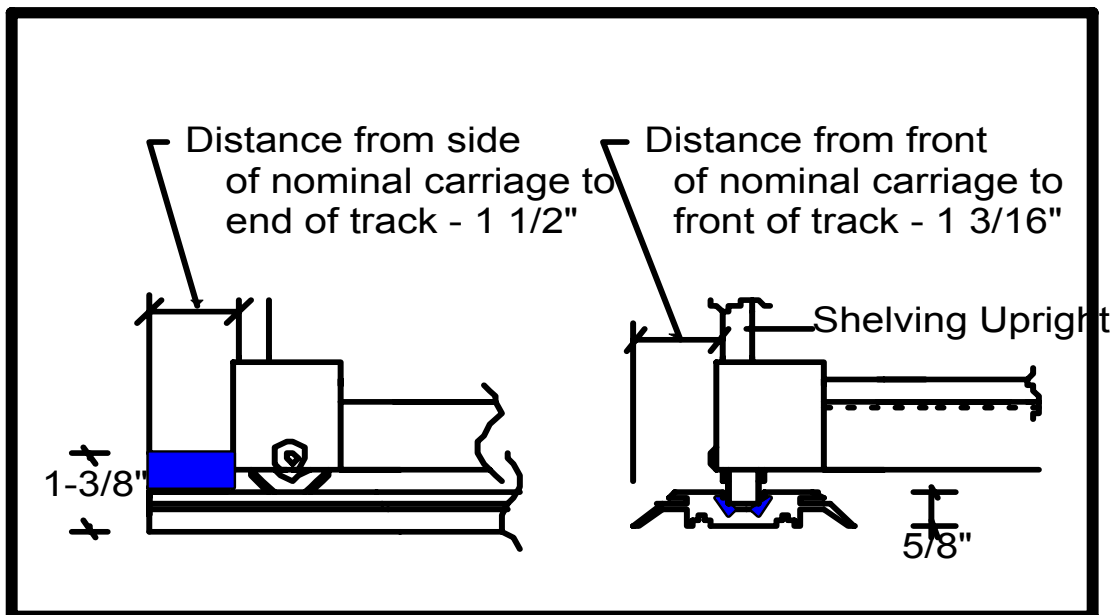
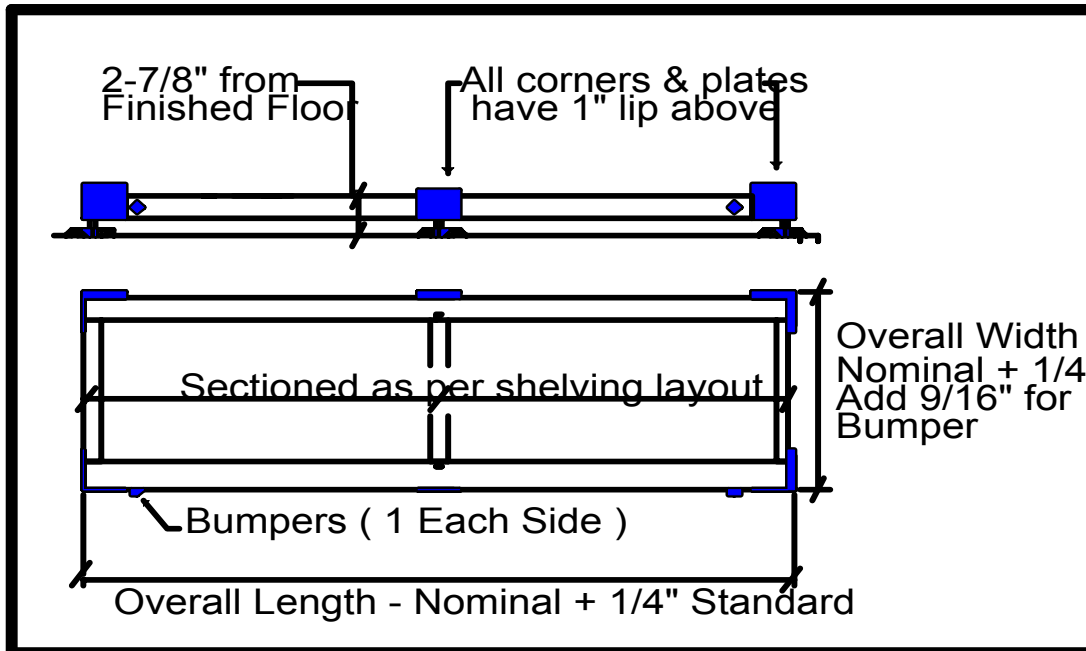



Compacted Anti-Tip

Specifications

Industry standards generally state that when the shelving height exceeds four times (4x) the depth, an anti-tip (AT) system is required.

Depending on the height-to-depth ratio and the overall weight in the system either floor or compacted anti-tip can be used.

Compacted Anti-tip

Mobile Media's compacted AT system uses a 7/8" steel tube completely enclosed in three (3) concave wheels.

The tolerance between the wheels and tube is designed to eliminate vertical deflection of the shelving unit before engagement of the AT system.

Because the system utilizes ball bearing wheels (not plastic or rubber grommets) there is no resistance to the movement of the system due to the AT system.

The ball bearings used are completely sealed and pressed into 2" diameter polypropylene concave wheels.

All three (3) wheels are secured to a solid steel angle. The angle is attached to the upright of the shelving unit (not the top shelf) for maximum stability.

Depending on the length of the carriage this system can be used on one or both ends and/or incrementally throughout the system.

Compacted Anti-Tip

Specifications

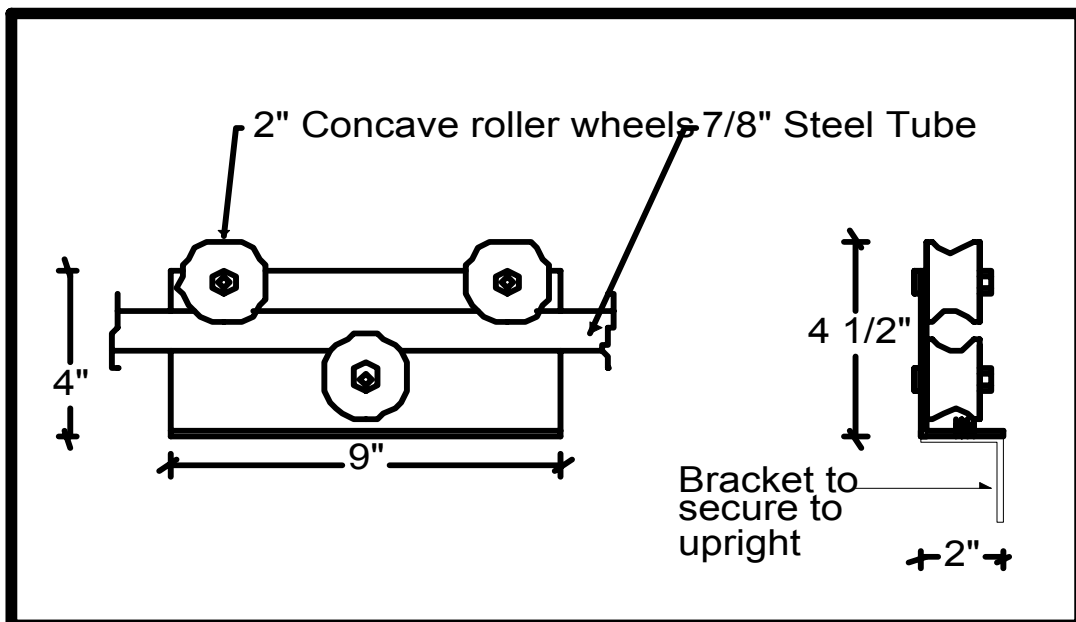
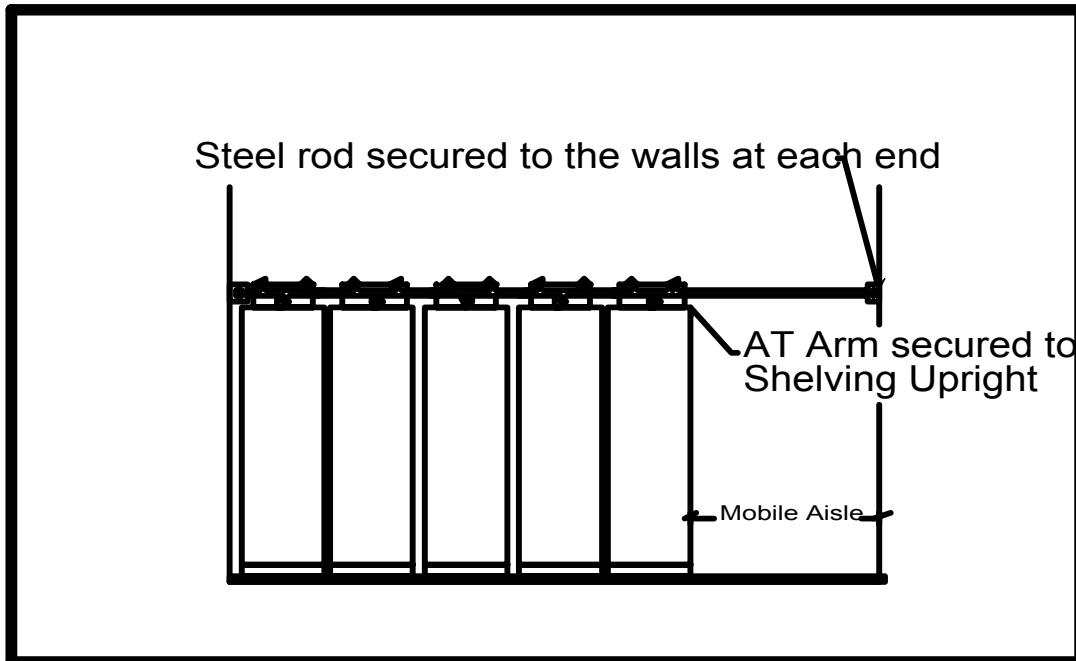



Deck Detail & Seismic Detail

Specifications

Deck Detail

All tracks used for the addition of a deck are 5/8" high. The front track on all systems has one side with a slot for the addition of a ramp.

All other tracks are at a 90 degree angle for the addition of a deck.

To prevent chipping of the floor tile the finished height of the track should be 1/8" above the track.

There are two choices for plywood for a finished deck - 5/8" and 3/4". We will discuss the layout using 3/4" below. Allowances will be made when using 5/8" plywood or carpet.

A deck spacer of 3/8" (to match the width of the track) is installed underneath the track. This makes the finished height of the track 1".

The 3/4" deck with the addition of a 1/8" tile will have a finished height of 7/8".

This will attain the desired result of the track being 1/8" above the deck.

Changes are made when using carpet or 5/8" plywood to reach the same end result.

Seismic Detail

When the system is being installed in a seismic zone, individual applications warrant custom calculations.

Modifications have been added to our standard floor anti-tip to meet generic seismic requirements.

Back to back shelving must be used to prevent side to side swaying. A 2" angle is provided at all corners for the attachment of the shelving to the carriage.

Please call for additional seismic information.

Deck Detail & Seismic Detail

Specifications

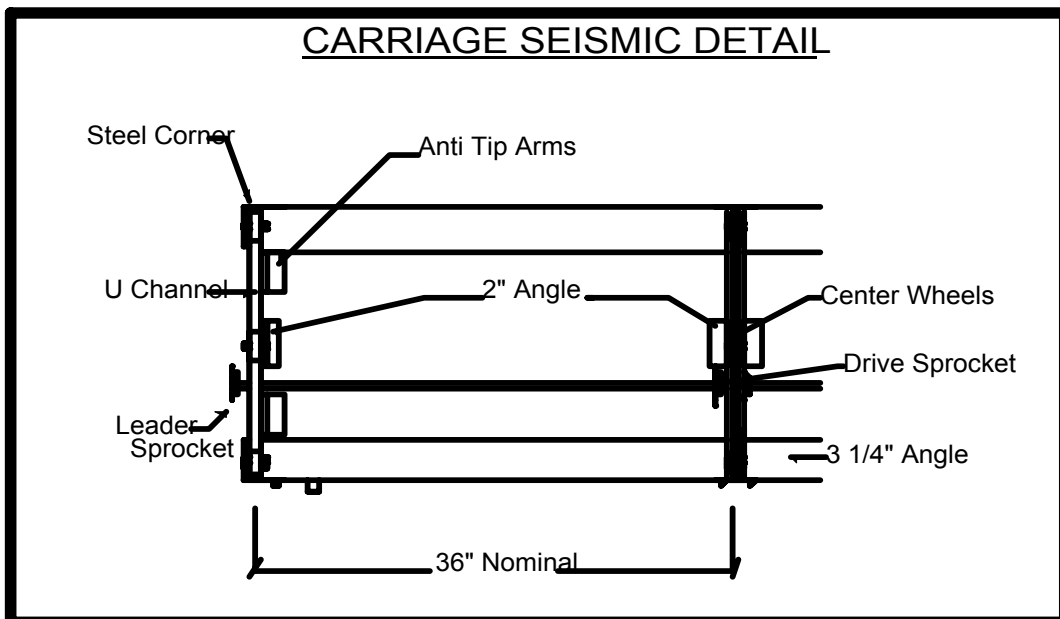
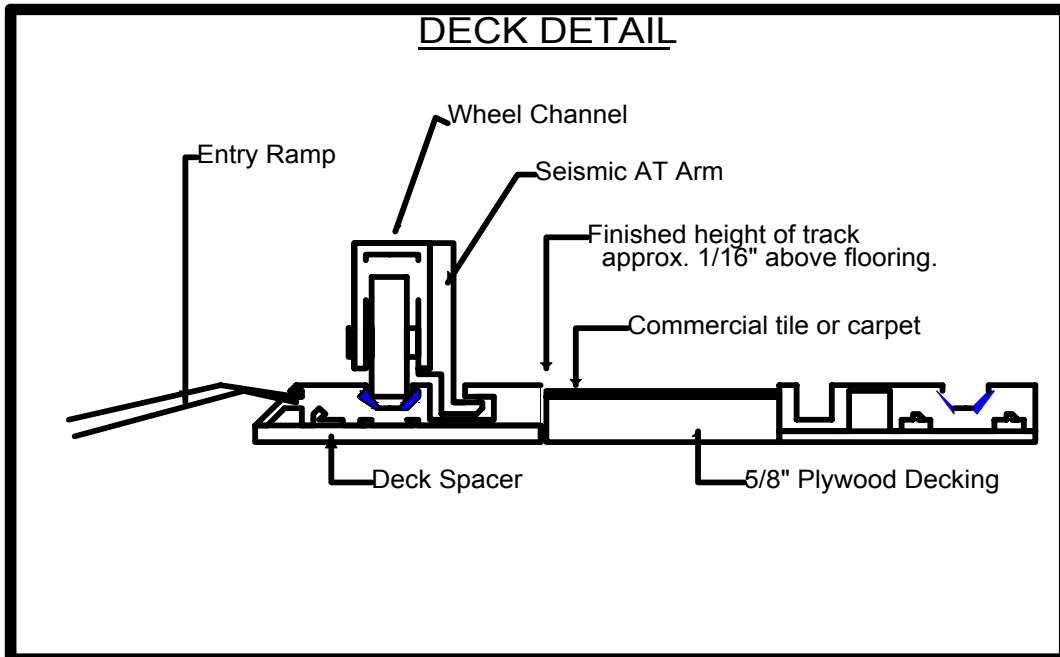



Wire Dividers

Specifications

In broadcast applications tape separation is sometimes an issue. Custom wire dividers are available.

The amount of required openings, length, width and depth are all variables to the cost. The amount of tapes per slot varies from one to three (1 - 3) standard. Tape dividers made of wire provide permanent separation and also provide a lip to prevent movement of the tapes when moving a mobile carriage.

Dividers are available in a variety of color choices to match new or existing shelving. Standard colors are tan, black, and white. Matching a custom color will affect lead price and lead times.

The chart on the left page will walk you through the information needed for pricing and manufacturing of the wire dividers.

Wire Dividers

Specifications

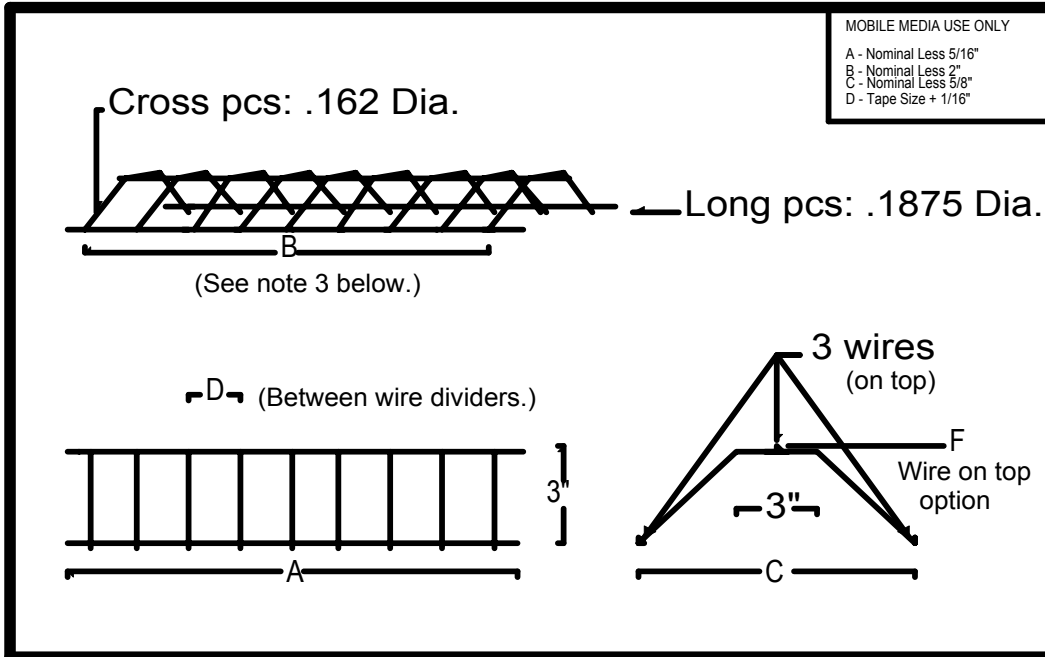

QUANTITY	A	B	C	D	E # of Openings	F

Notes: 1. The numbers of openings centered on B measurement should be centered on A.
 2. Wire to be .125" thick. Please specify thickness if not matching exact.
 3. To not loose any space and use the full distance of B - after using the space of D x E, use remaining space left in B in last opening on 1 side